



Features and Benefits

- Very low G sensitivity (up to 0.15 ppb/g)
- High frequency stability (up to 0.5 ppm over -40°C to +85°C)
- CMOS square wave output
- Compact 5 x 7 mm design

Typical Applications

- Harsh and rugged environment
- Mobile Microwave Applications

Description

TCXO7500ZLGSQ series offers high shock resistant (>5'000 g), wide temperature operation from -40°C to +85°C with outstanding frequency stability and low phase noise performance all in one compact package.

Mechanical Drawing & Pin Connections

Drawing No: MD1) \$\$+) !()

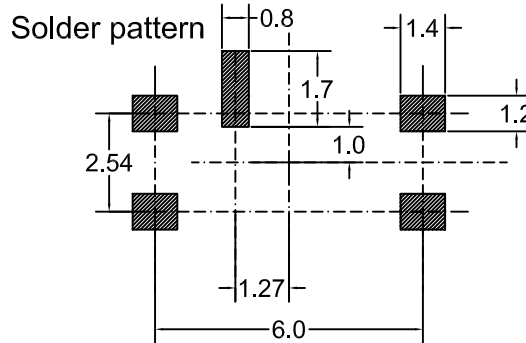
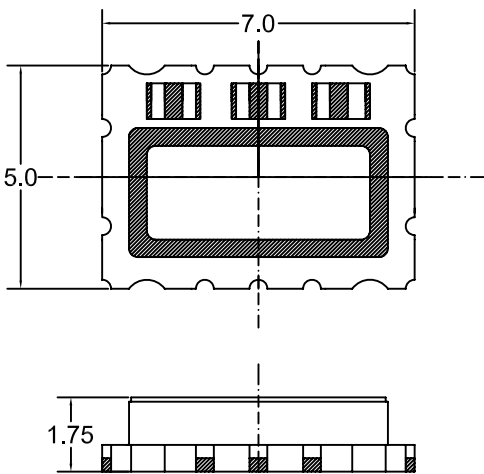

Pin Function

- #1 Vc(EFC)
- #5 GND
- #6 Output
- #9 NC or E/D
- #10 Vcc

Do not connect #2, #3, #4, #7, #8

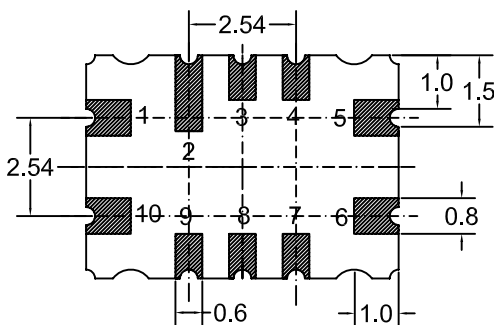

Test Circuit

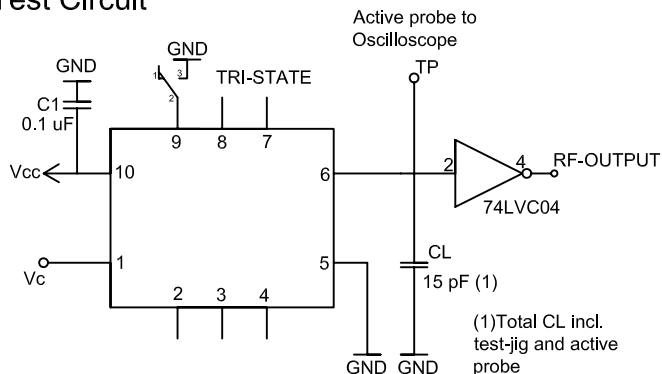

Unit in mm
1mm = 0.0394 inches



Specifications

Oscillator Specification	Sym	Condition	Value			Unit	Note
			Min.	Typ.	Max.		
Standard Frequencies			10.000, 12.000, 13.000, 15.360, 16.368, 20.000, 25.000, 27.000, 40.000			MHz	Other frequencies available on request
G-sensitivity		Gamma Γ		≤ 0.50 ≤ 0.15		ppb/g	Standard On request
Frequency Slope		Over operating temperature		≤ 0.05		ppm/ $^{\circ}$ C	
Output Signal			CMOS				
Output Level			$V_{OH} > 0.9 \times VCC$ $V_{OL} < 0.1 \times VCC$				
Output Load					15	pF	
Tri-state Function		Pin #9 or open Pin #9 or GND		≥ 3.5 ≤ 0.9		V	Pin #6 \rightarrow oscillation Pin #6 \rightarrow high impedance
Power Supply							
Supply Voltage	V_{cc}		+2.8 or +5.0			V	Standard 2.8V, 3.0V, 3.3V, & 5.0V
Current Consumption			2 ~ 6			mA	
Frequency Control							
Electronic Frequency Control (EFC) range	ΔF			$> \pm 8$		ppm	
EFC Voltage	V_c			+1.5		V	$\pm 1.0V$, other V_c on request
Frequency Stability							
Vs Temperature Reference to $(F_{MAX} + F_{MIN})/2$		Over -40° C to $+85^{\circ}$ C		$\leq \pm 1.0$ $\leq \pm 0.5$		ppm	Standard On request
Frequency Tolerance ex-factory		@ $+25^{\circ}$ C	+0.5 ~ +1.5			ppm	
Vs Supply Voltage changes reference to frequency at nominal supply		$\pm 5\%$		$\leq \pm 0.1$		ppm	
Vs Load changes Reference to frequency at nominal load		$\pm 10\%$		$\leq \pm 0.1$		ppm	
Vs Aging - 1 st year - 5 years				$\leq \pm 1.0$ $\leq \pm 3.0$		ppm	
Phase noise@20 MHz		100 Hz		-120		dBc/Hz	
		1 KHz		-145			
		10 KHz		-155			
		100 KHz		-155			
Short-Term Stability ADEV		Tau = 1 sec		$< 1 \times 10^{-10}$			
Environmental Conditions							
Operating temperature range			-40° C to $+85^{\circ}$ C				
Storage temperature range			-55° C to $+105^{\circ}$ C				
Reflow Profiles as per IPC/JEDEC J-STD-020C			$\leq 260^{\circ}$ C over 10 sec. max.				
Moisture Sensitivity			Level 1 (unlimited)				



Measurement of the G-Sensitivity

1 Vibration Profile – Random

Noise shape vibration from 10-2000 Hz with 0.01 g²/Hz ($G_{RMS} = 4.46g$) was also measured at 0.1 g²/Hz ($G_{RMS} = 14.11g$) for the axis with very small G-Sensitivity.

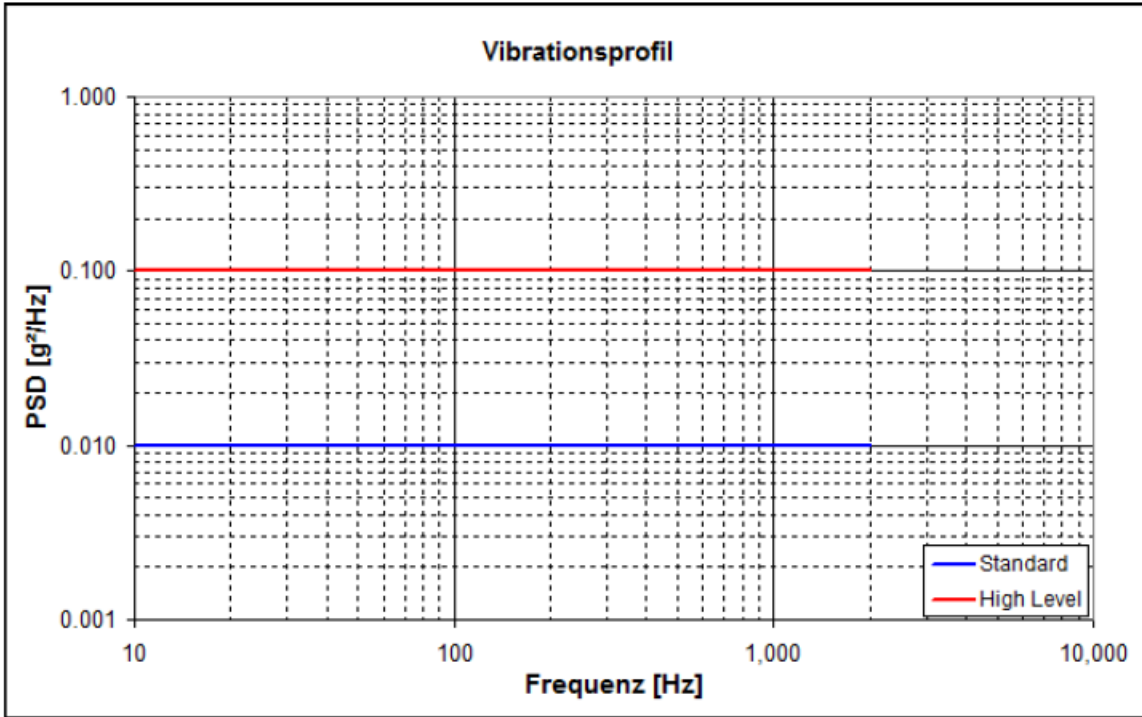

Fig.1 – Vibration profile (Power Spectral Density)

2.1 Definition of the axes

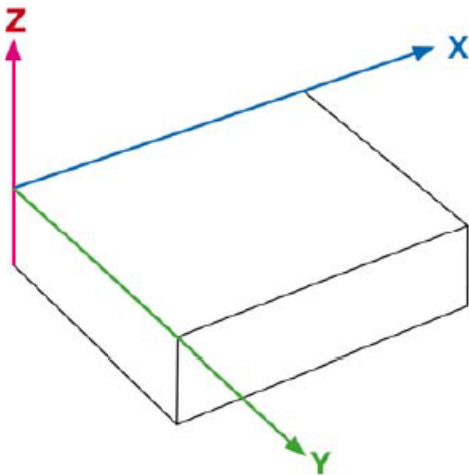
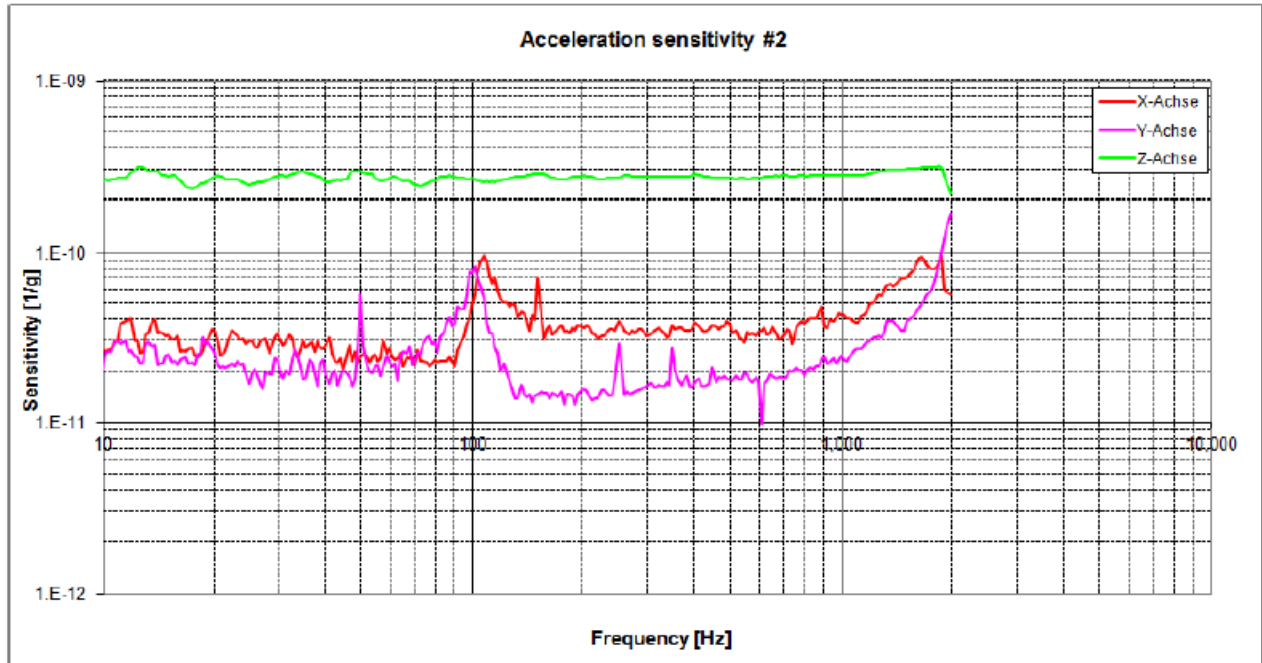

Fig 2



GGG-Sensitivity averaged 10 Hz – 2000 Hz

Oscillator Number	10.000 MHz			
	X-Axis [1/g]	Y-Axis [1/g]	Z-Axis [1/g]	Gamma Γ [1/g]
1	1.79E-11	1.92E-11	1.69E-10	1.71E-10
2	3.41E-11	2.27E-11	2.70E-10	2.73E-10
3	1.05E-10	2.71E-11	8.88E-11	1.40E-10



Osz #2

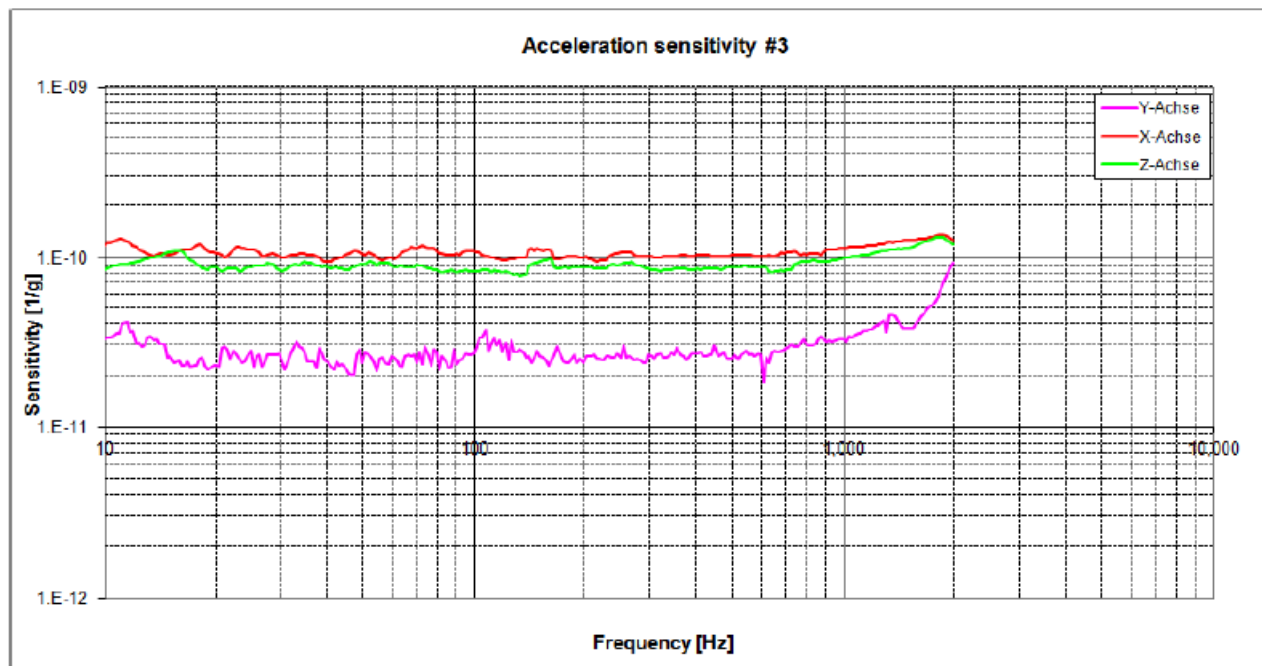

Osz #3



12.000 MHz				
Oscillator Number	X-Axis [1/g]	Y-Axis [1/g]	Z-Axis [1/g]	Gamma Γ [1/g]
1	6.01E-11	2.43E-11	2.10E-10	2.20E-10
2	7.48E-11	1.80E-11	1.61E-10	1.78E-10
3	3.37E-11	2.71E-11	3.18E-10	3.21E-10

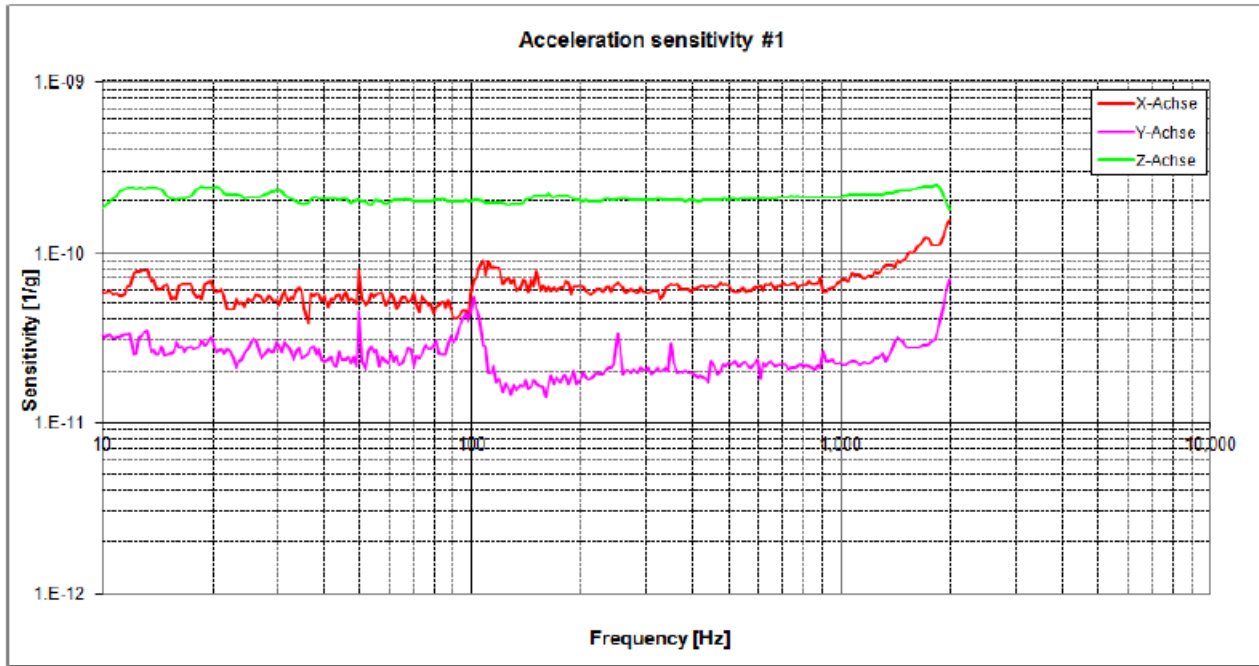

Osz #1

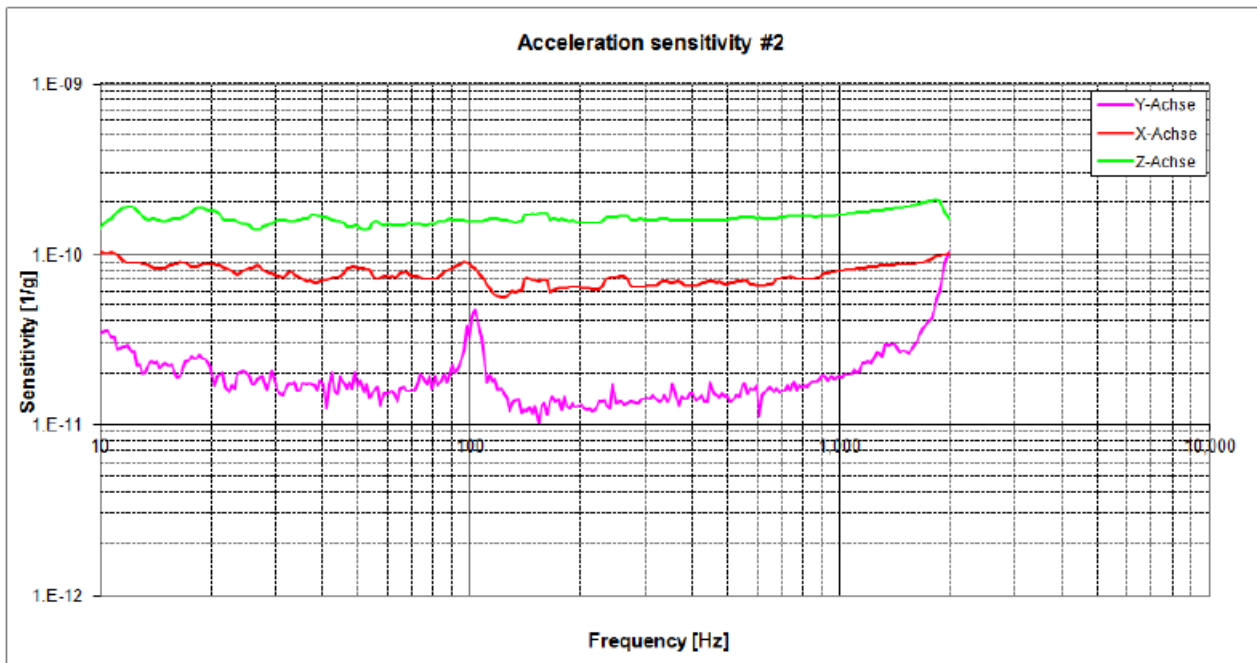

Osz #2



13.000 MHz				
Oscillator Number	X-Axis [1/g]	Y-Axis [1/g]	Z-Axis [1/g]	Gamma Γ [1/g]
1	2.06E-11	2.22E-11	3.26E-10	3.28E-10
2	3.44E-11	2.78E-11	3.27E-10	3.30E-10
3	2.79E-11	2.96E-11	3.48E-10	3.50E-10

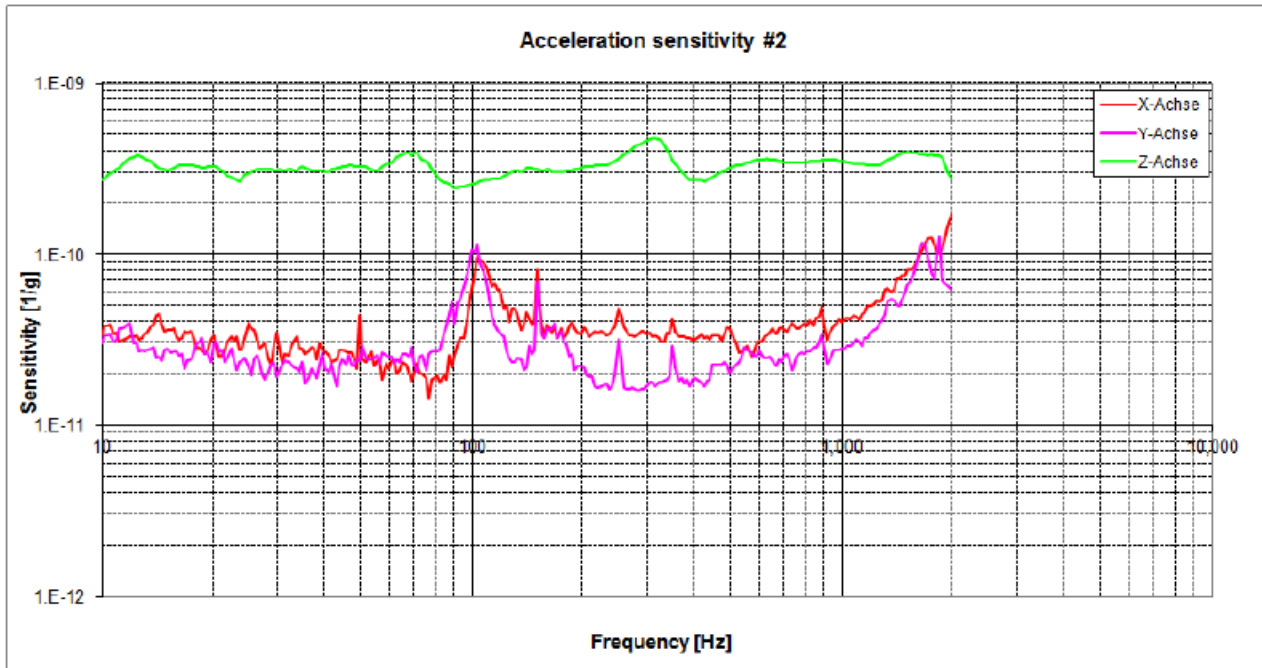

Osz #2

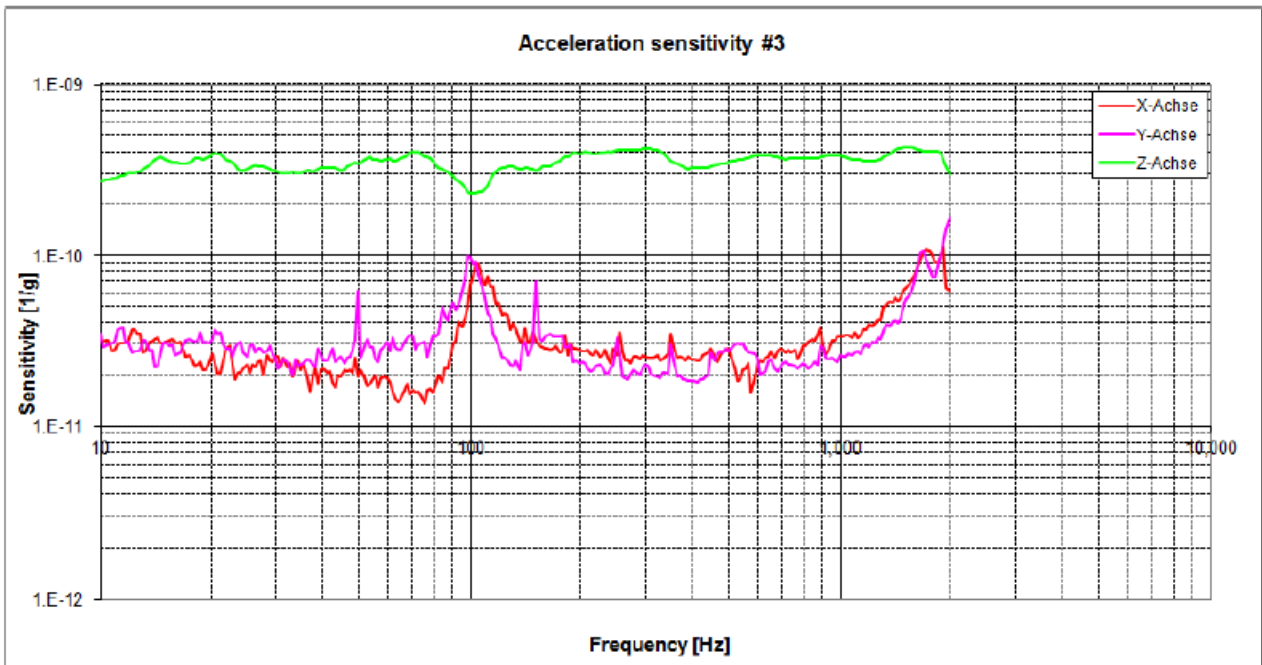

Osz #3



20.000 MHz				
Oscillator Number	X-Axis [1/g]	Y-Axis [1/g]	Z-Axis [1/g]	Gamma Γ [1/g]
1	2.67E-11	4.55E-11	3.55E-10	3.59E-10
2	2.61E-11	8.59E-11	4.09E-10	4.19E-10
3	4.88E-11	8.60E-11	2.55E-10	2.73E-10

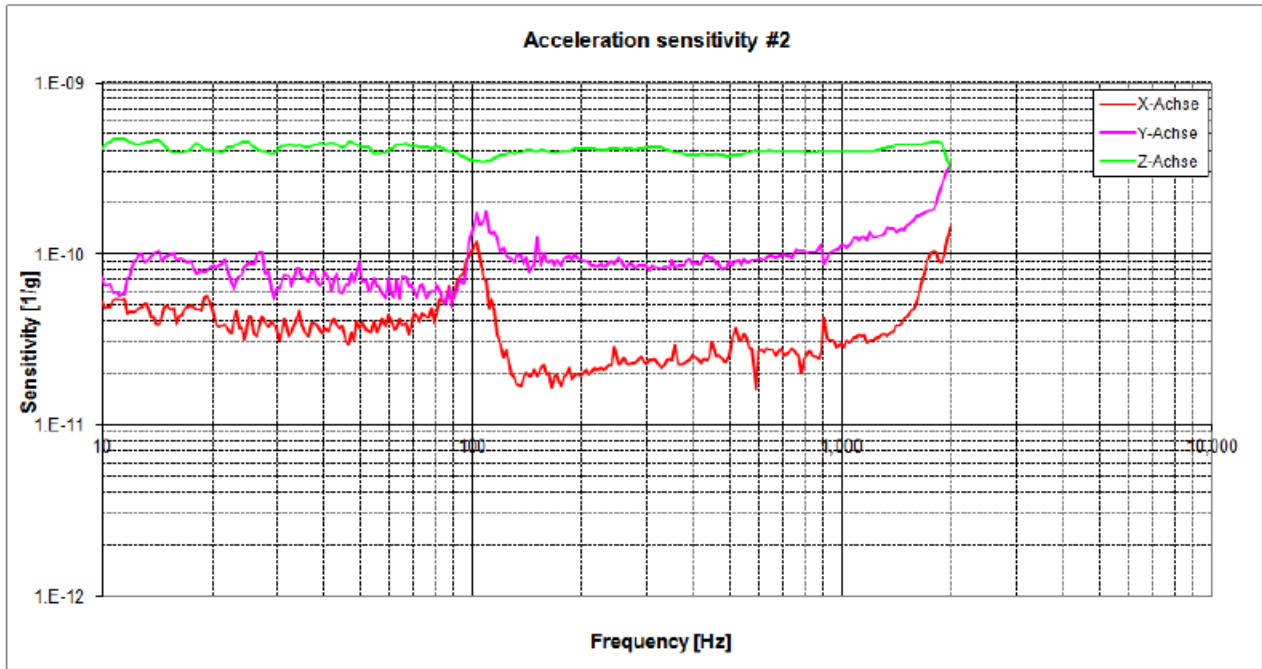

Osz #2

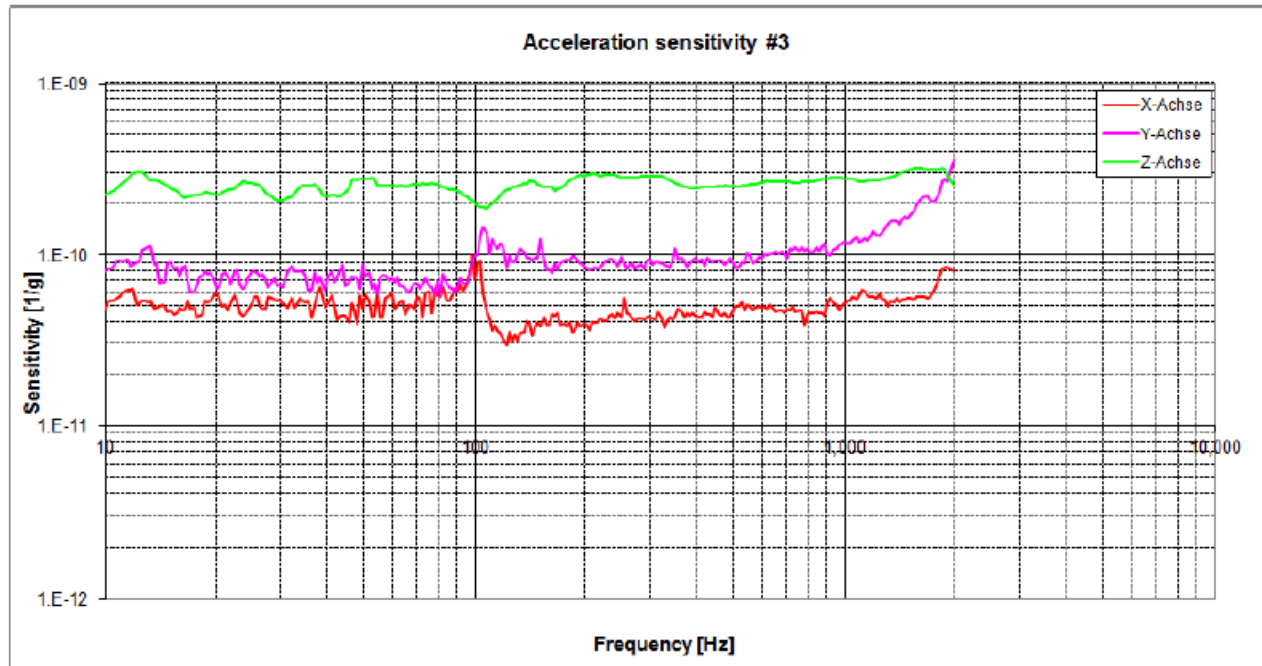

Osz #3



25.000 MHz				
Oscillator Number	X-Axis [1/g]	Y-Axis [1/g]	Z-Axis [1/g]	Gamma Γ [1/g]
1	5.84E-11	4.78E-11	3.13E-11	8.17E-11
2	6.15E-11	6.41E-11	3.78E-10	3.88E-10
3	3.03E-11	5.52E-11	4.69E-10	4.73E-10

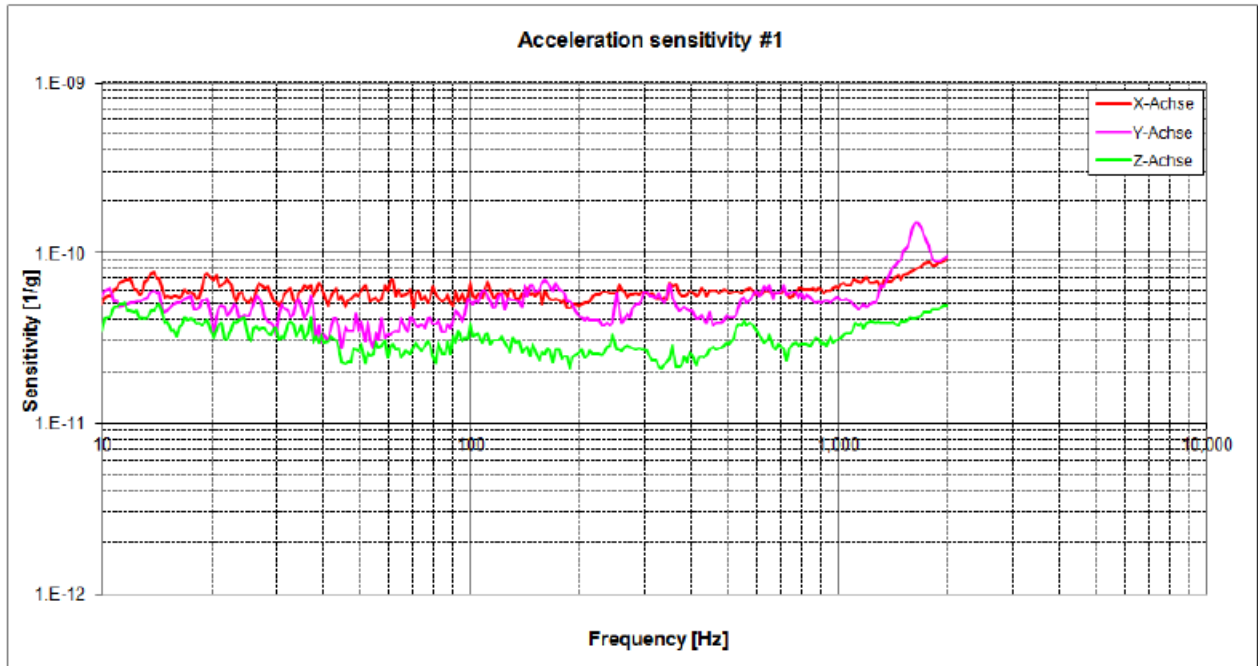

Osz #1

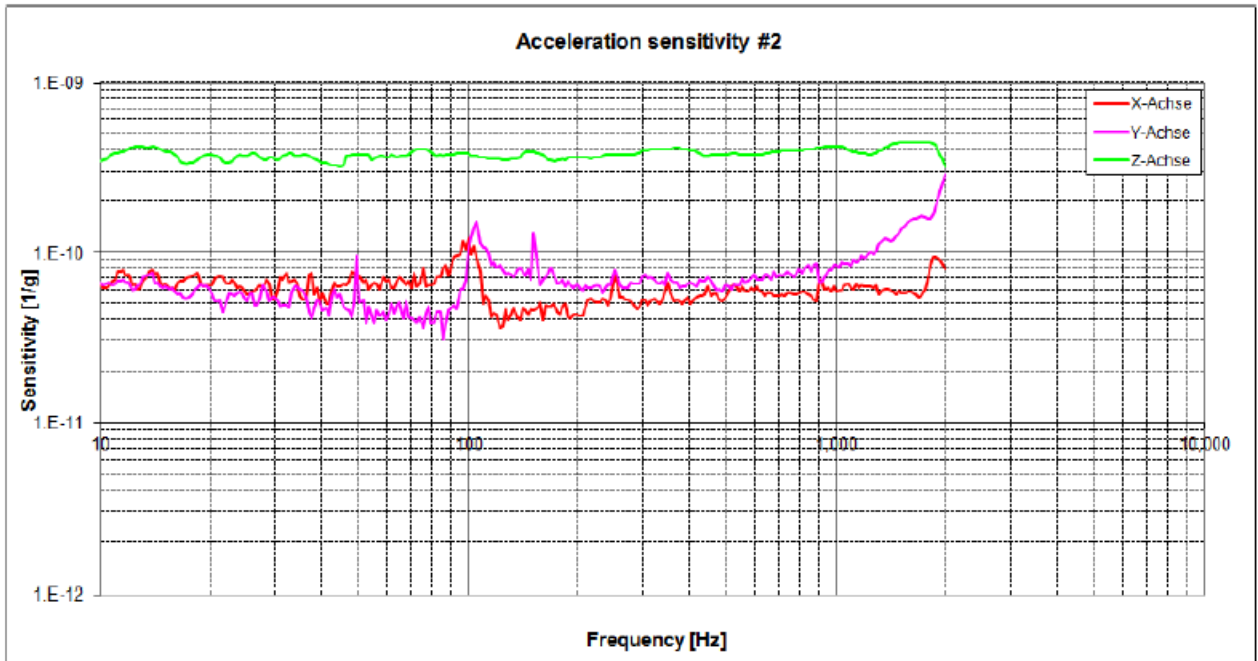

Osz #2



40.000 MHz				
Oscillator Number	X-Axis [1/g]	Y-Axis [1/g]	Z-Axis [1/g]	Gamma Γ [1/g]
1	5.46E-11	9.31E-11	3.31E-10	3.48E-10
2	5.82E-11	9.43E-11	3.48E-10	3.65E-10
3	5.87E-11	5.01E-11	3.45E-10	3.54E-10

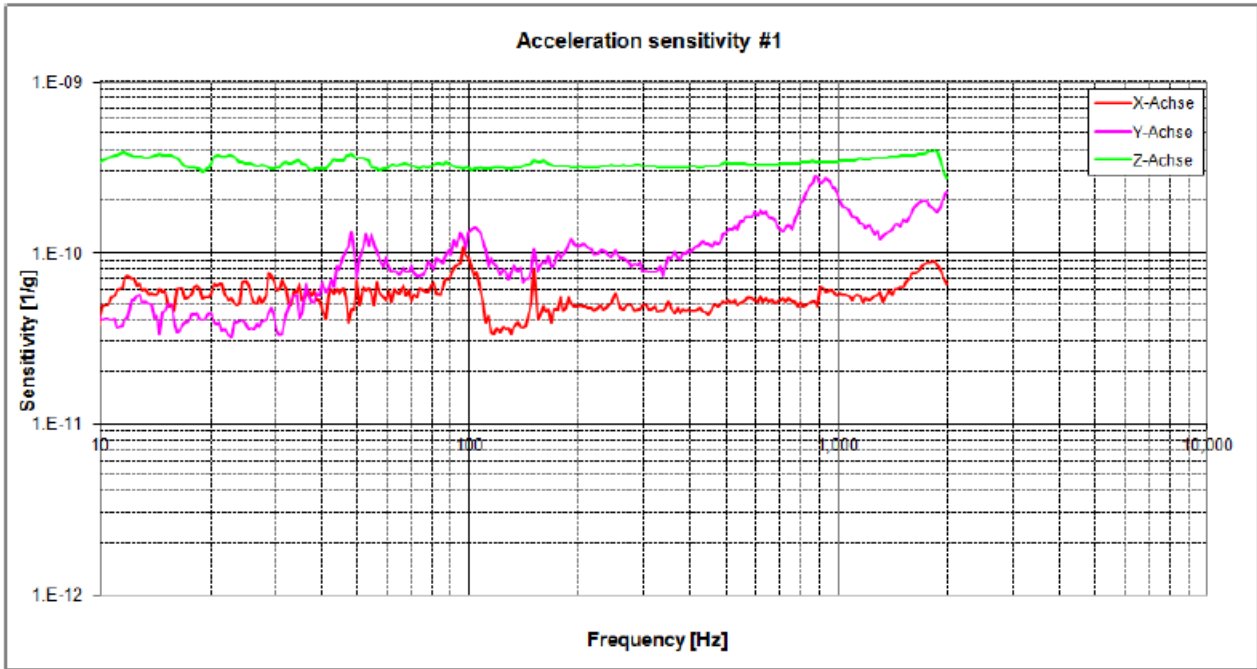

Osz #1

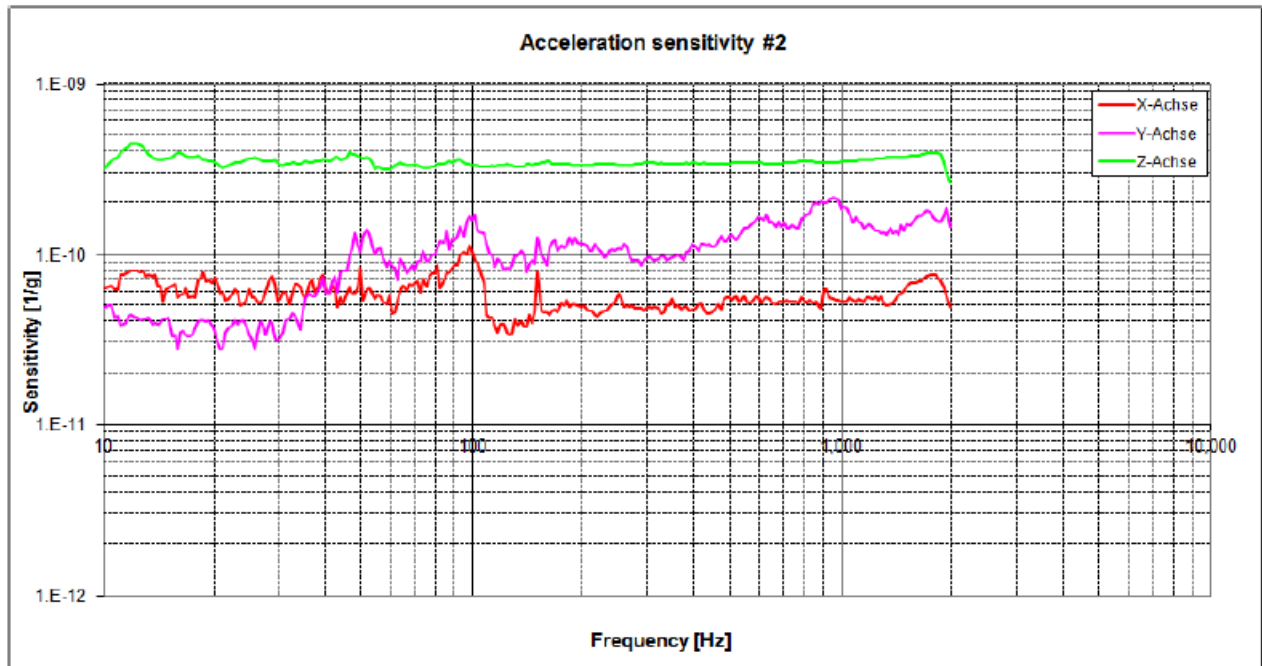

Osz #2



Environment Conditions

Test	IEC 60068 Part...	IEC 60679-1 Clause	MIL-STD-202G Method	MIL-STD-810F Method	MIL-PRF-55310D Clause	Test Conditions (IEC)
Sealing Tests (if applicable)	2-17	5.6.2	112E		3.6.1.2	Gross leak; Test Qc, Fine leak; Test Qk
Solderability	2-20	5.6.3	208H		3.6.52	Test Ta method 1
Resistance to soldering heat	2-58		210F		3.6.48	Test Td ₁ method 2 Test Td ₂ method 2
Shock	2-27	5.6.8	213B	516.4	3.6.40	Test Ea, 3 x per axis, 100 g. 6ms half-sine pulse
Vibration sinusoidal	2-6	5.6.7.1	201A 204D	516.4-4	3.6.38.1 3.6.38.2	Test Fc, 30 min per axis, 1 oct/min 10 Hz – 55 Hz 0, 75mm, 55 Hz – 2 kHz, 10 g
Vibration random	2-64	5.6.7.3	214A	514.5	3.6.38.3 3.6.38.4	Test Fdb
Endurance tests			108A			
- Aging		5.7.1			4.8.35	30 days @ +85°C
- Extended aging		5.7.2				1000 h, 2000 h, 8000 h @ +85°C