



Features and Benefits

Frequency range: 13.5-50MHz,65-220MHz
Supply voltage: 2.5V,3.3V
Steady current: 35mA Max.
Output waveform: LVDS
Frequency stability vs. operating temperature: ±25ppm
RMS jitter: 98fs
Operating temperature: -40°C to + 85°C
Size: 7x5x1.8mm

Typical Applications

SatCom
Test equipment
Network clock
Base station

Description

The XO7500AJ_LVDS series are designed for applications where exceptional frequency stability and timing is required. It has both excellent temperature performance and short term stability. These characteristics make it an excellent choice for timing applications.

Mechanical Drawing & Pin Connections

Drawing No: MD160041-4

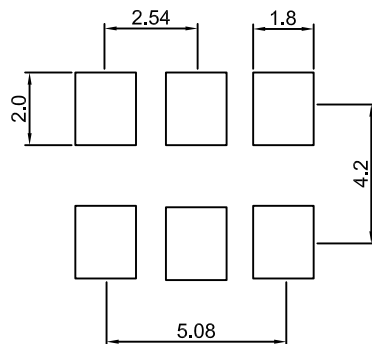
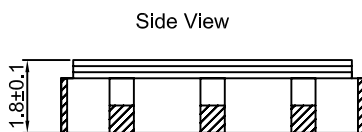
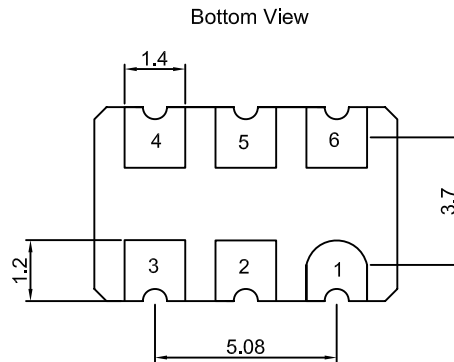
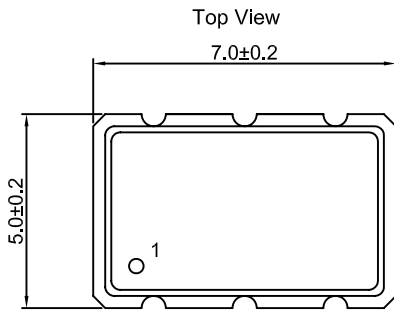

Pin Connection

Pad 1	OE
Pad 2	N.C.
Pad 3	Ground
Pad 4	Output
Pad 5	Complementary
Pad 6	Supply Voltage

Unit in mm
1mm = 0.0394 inches

Land Pattern



Specifications

Oscillator Specification	Sym	Condition	Value			Unit	Note
			Min.	Typ.	Max.		
Frequency Range	F _{nom}		13.5		50	MHz	
			65		220	MHz	
RF Output							
Signal Waveform			LVDS				
Level		Logic " High " , " 1 "		1.4	1.6	V	
		Logic " Low " , " 0 "	0.9	1.1		V	
Load		between output and complimentary output	100			Ω	
Duty Cycle			50% ± 5%				
Output Voltage Swing		Single end	250			mV	
Rise Time / Fall Time		20%↔80%		0.2	0.4	ns	
Output Enable/Disable Function		Enable	70%(min.)of Vdd to enable output Enable time:10msec(max.)				
		Disable	30%(max.)of Vdd to disable output Disable current:10uA(max.) (OE<=0.3V), Disable time:0.2usec(max.)				
Power Supply							
Supply Voltage	Vdd	± 10%		2.5		V	
	Vdd	± 10%		3.3		V	
Current consumption				15	35	mA	
Start-up Time				1	5	ms	
Frequency Stability							
Versus Operating Temperature Range						ppm	See ordering information
Aging 1 st Year		at 25°C			±3	ppm	
Phase Noise		100Hz(50MHz)		-104		dBc/Hz	
		(156.25MHz)		-93		dBc/Hz	
		1KHz(50MHz)		-134		dBc/Hz	
		(156.25MHz)		-123		dBc/Hz	
		10KHz(50MHz)		-147		dBc/Hz	
		(156.25MHz)		-140		dBc/Hz	
		100KHz(50MHz)		-153		dBc/Hz	
		(156.25MHz)		-149		dBc/Hz	
		1MHz(50MHz)		-152		dBc/Hz	
		(156.25MHz)		-152		dBc/Hz	
RMS Jitter (12 KHz to 20 MHz)		<100MHz	350 fsec typ. (50MHz,3.3V,LVDS)				
		>100MHz	98 fsec typ. (156.25MHz,3.3V,LVDS)				
Environmental, Mechanical Conditions							
Storage Temperature		-55°C to + 150°C					



Ordering Information

XO7500AJ_LVDS	-	20MHz	-	x	x	x
Group				01	02	03

For example, XO7500AJ_LVDS-20MHz-1-1-1 denotes the XO has the following specifications:

Temperature Range: -10°C to +70°C
 Stability Over Temperature: ±25ppm
 Supply Voltage: 2.5V
 Frequency: 20MHz

option 01	Temperature Range
Code	Specification
1	-10°C to +70°C
2	-40°C to +85°C

option02	Frequency Stability (If non-standard, please contact DEI)
Code	Specification
1	±25ppm
2	±50ppm
3	±100ppm

option 03	Supply Voltage
Code	Specification
1	2.5V
2	3.3V